

P 900 *TopClass*

PALFINGER

LIFETIME EXCELLENCE

NEW OUTREACH IN NEW HEIGHTS. THE MOST STATE-OF-THE-ART TECHNOLOGY OFFERED BY THE GLOBAL MARKET.



OUTREACH

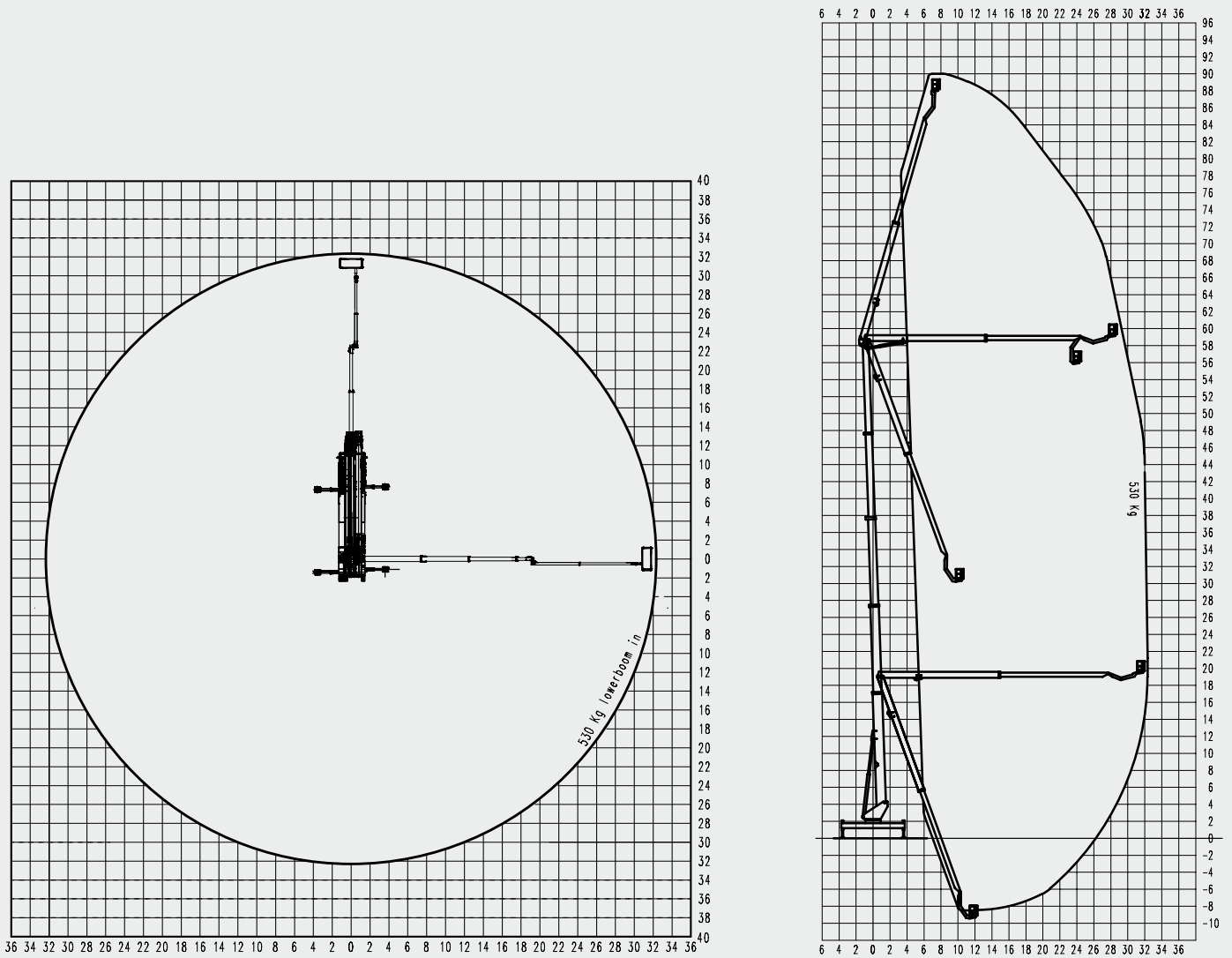

DIMENSIONS

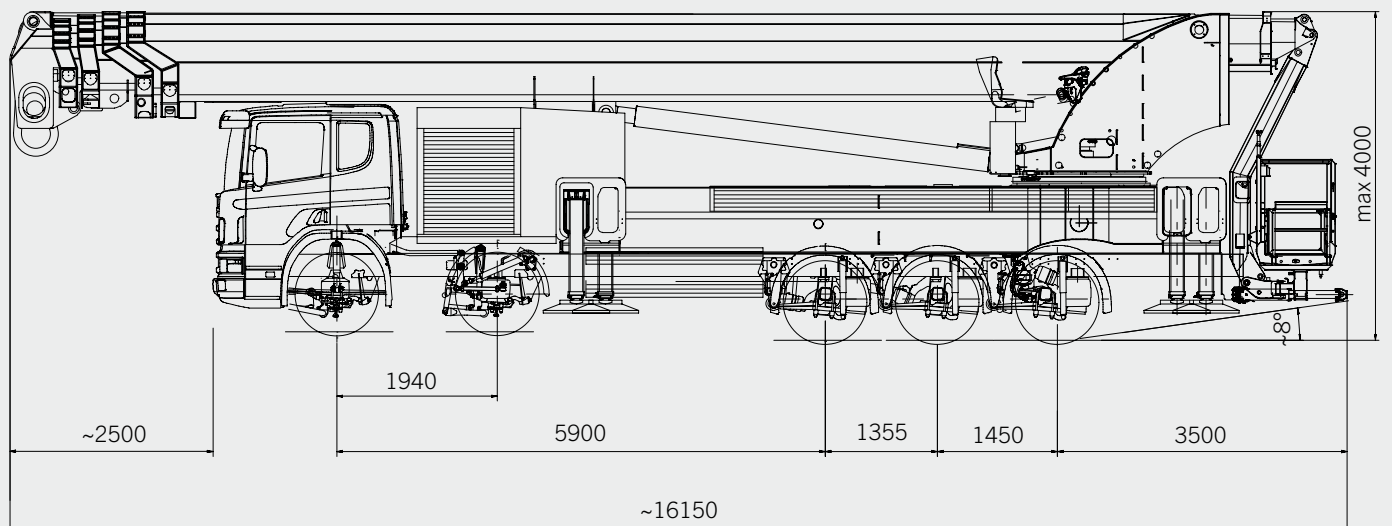



- Maximum cage boom rotation of 180°
- Maximum basket load up to 700 kg
- Maximum vertical range up to 90 m
- The latest technology combined with a snappy design
- Easy, user-friendly handling and operator comfort
- Top-class equipment
- Total weight below 48 t with sufficient loading capacity
- Equipped for long periods of use
- Cost-effective

TECHNICAL SPECIFICATIONS

Max. working height	90 m
Max. basket floor height	88 m
Max. horizontal range of standard basket	32.3 m
Boom system	
Hydraulic jib boom, working range	180°
Hydraulic upper boom, working range	162°
Workman basket	
Standard basket: Telescopic basket (WxLxH)	2.15 / 3.45 x 0.95 x 1.15 m
Slewing range of basket	2 x 84°
Nominal load in telescopic workman basket	530 kg
Nominal load in heavy-duty basket (optional)	700 kg
Stabilizers	
Function and type of stabilizers	fully variable hydraulic H-type stabilizers
Max. stabilizer spread - both sides horizontally extended	8 m
Carrier vehicle and installation	
GVW class	48000 kg
Length in transport position	16.15 m
Height in transport position	4.0 m
Slope angle	8°

STANDARD EQUIPMENT

Large storage compartment with lighting for tools and materials
Secondary control at the turntable
Illumination of the jacking area
Graphic colour display in the operating panels
Multiple emergency lowering systems from the basket and base
Collision protection for workman basket and jib boom (attachment device)
Emergency drive via electrical pump
Automatic stabilizer and levelling systems

LIFETIME EXCELLENCE

THE RESULT IS **PALFINGER ACCESS PLATFORMS** FEATURING THE MOST STATE-OF-THE-ART HEIGHT TECHNOLOGY THAT ACHIEVE ABSOLUTE PEAK PERFORMANCES, EVEN WHEN CONFRONTED WITH THE MOST DIFFICULT OF JOBS IN PRACTICE. **DEVELOPED FOR THE GLOBAL MARKET, DESIGNED FOR THE FUTURE.**

BETTER
SOLUTIONS

BETTER
EFFICIENCY

BETTER
ERGONOMICS

HIGHER VALUE
RETENTION

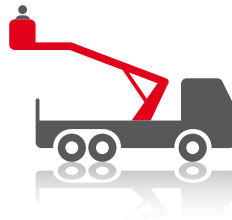

HIGHER
AVAILABILITY

HIGHER
SERVICEABILITY

BETTER
ECOLOGY

MORE
RELIABILITY

For further information please visit: www.palfinger.com/thebrand