

Masted forklifts
trucks

MC 60/70
POWERSHIFT

Heavy duty yard forklifts

- Capability 6000 kg and 7000 kg
- Lifting height of 3.60 m to 4.50 m



 **MANITOU**

MC 60 Powershift MC 70 Powershift



Lifting capability

MC 60 Powershift.....6000 kg
MC 70 Powershift.....7000 kg
600 mm from the forks



Standard lifting height

.....4.00 m
Speed empty/ laden (m/s)
MC 60 Powershift
Lifting0.40/0.36
Lowering0.43/0.50
MC 70 Powershift
Lifting0.38/0.33
Lowering0.37/0.43



Tyres

Front18 R 19.5 XF Tubeless (445/65 R 19,5)
Rear9.5 R 19.5 Tubeless XZA 134/131 K



Forks (mm)

Length1500
Width x thickness150x70



Hydraulic oil bath multidisk brakes on the front axle



PERKINS engine

Type1104C-44
Capacity4 cyl. - 4400 cm³
Nominal engine speed2200 r.p.m.
Power at (ISO/TR 14396)84 HP (61.5 Kw)
Maximum torque.....302 Nm at 1400 r.p.m.
Direct injection
Water cooled



Transmission

.....Powershift
Electro-hydraulic reversing shift
4 forward and 3 reverse gears
Maximum travelling speed24 km/h
Electro-hydraulic differential lock



Hydraulic

Main gear pump
Pressure/flow230 bar/89 l./mn
Priority flow divider for steering145 bar/89 l./mn



Capacity

Cooling system.....19 l.
Engine oil8.5 l.
Hydraulic oil108 l.
Transmission oil12.5 l.
Fuel115 l.



Weight (with forks)

MC 60 Powershift.....9055 kg
MC 70 Powershift.....9700 kg

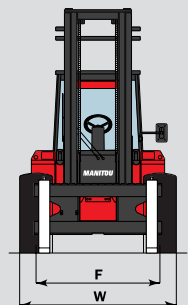
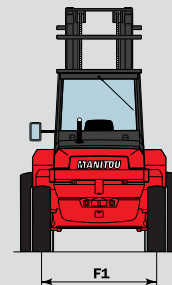
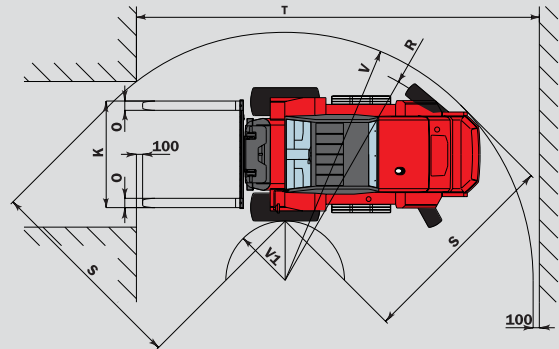
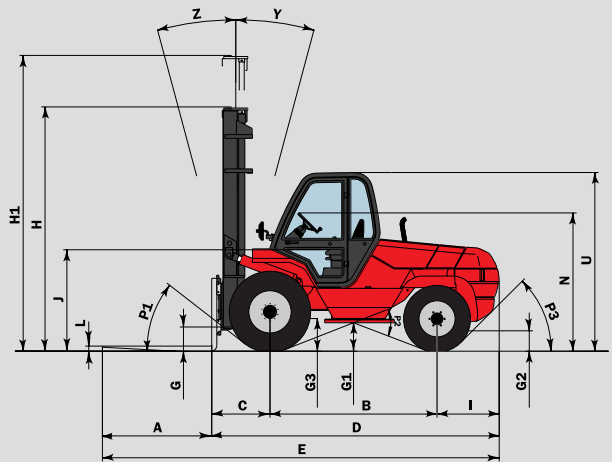

	MC 60 Powershift	MC 70 Powershift
A	1500	1500
B	2293	2493
C	803	803
D	3960	4160
E	5460	5660
F	1700	1700
F1	1580	1580
G	320	320
G1	390	385
G2	305	305
G3	390	390
H	3405	3405
H1	5405	5405
I	864	864
J	1390	1390
K	1750	1750
L	70	70
N	1860 à 1920	
O	150	150
P1	38°	38°
P2	42.5°	38.5°
P3	45°	45°
R	3625	3840
S	3460	3510
T	6500	6715
U	2440	2440
V	3995	4210
V1	760	995
W	2150	2150
Y	15°	15°
Z	15°	15°

Standard

- Enclosed cab with tinted windows
- Fabric-covered seat
- Adjustable steering column
- Heating
- Windscreen-wiper and front/rear windscreen-washer
- Exterior left-hand rear-view mirror
- Reversing shift on steeringcolumn
- Road lights front and rear including indicators
- Electro-hydraulic differential lock
- ...

Options

- Screen guard
- Rotating beacon
- Audible reverse alarm
- Working lights
- Wide carriages
- Various attachments such as buckets, TDL, grabs etc...

The equipment supplied with each model may differ from that described in this leaflet.
For more details, contact your MANITOU dealer.

mm
H-H1: Standard

