

HTH10.10

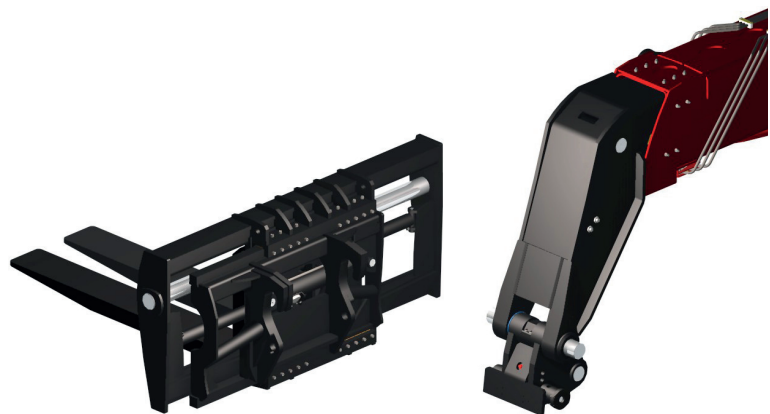

Load chart forklift with fork

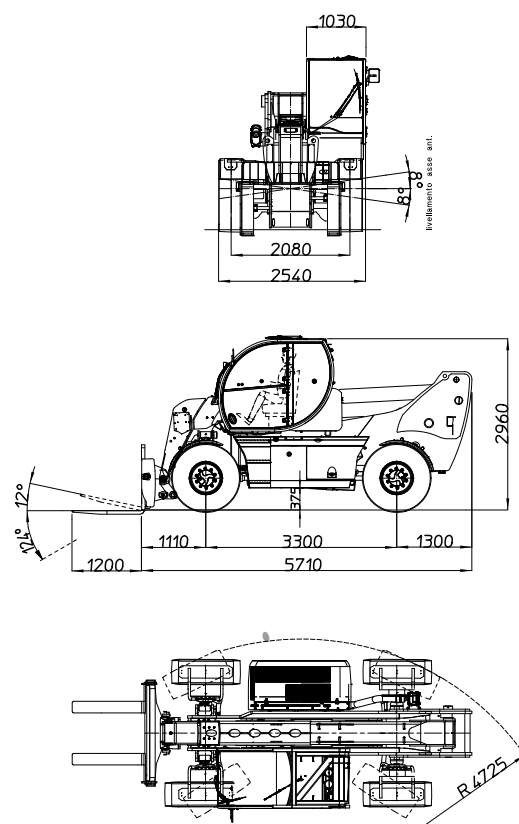
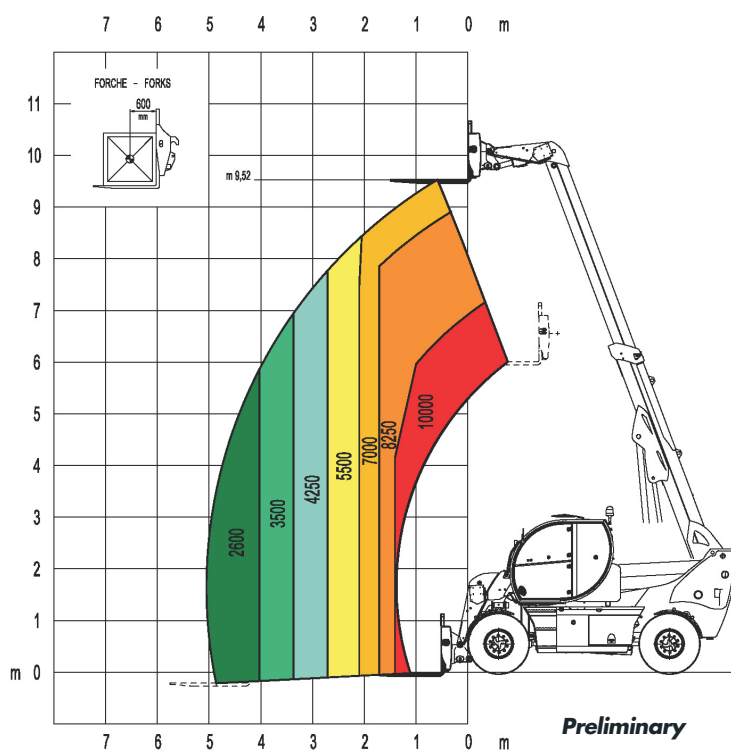

Clamp for wheels handling, with a capacity up to 8.000 kg from 24 to 63 inches .

- MAGNI patented quick fit of the attachment
- Attachments automatic recognition RFID system



LIFT CAPACITY	10.000 Kg at 600 mm load center	
MAXIMUM LIFTING HEIGHT	9.52m	
MAXIMUM REACH	5.05 m	
FORKS	Fork carriage with forks positioner 1.750 mm length Forks 200x60x1.200 mm	
CAB	FOPS-ROPS tested hermetic cab with protectors Front, rear and upper wiper Headlights for road circulation, flashing beacon Rear view mirrors Heating - Air conditioning	
CONTROLS	Multi-function electro proportional joystick	
BRAKE SYSTEM	Hydraulic servo-assisted multidisc brake in oil bath on both axles, with double circuit Negative parking brake	
ENGINE	JCB ECOMAX - stage 3B	JCB DIESELMAX - stage 3A
	Turbo intercooler	
	4 cylinders / 4.800 cm ³	4 cylinders / 4.400 cm ³
	Power 108 KW	
	Max rpm = 2.200	
	Max torque 560 Nm at 1.500 rpm	Max torque 550 Nm at 1.500 rpm
	Diesel turbocharged	
	Liquid cooling system	
AXLES	Heavy Duty with epicyclic reduction One steering cylinder each axle Levelling correction front axle at + 8° on the right and + 8° on the left 3 types of steering: - with front steering - with round steer - with crab steering Tilting rear axle	
PERFORMANCE	Max. travel speed: 40 km/h Drawbar pull: 88 kN Gradeability: 35% Turning radius (end of forks): 4.725 mm	
WEIGHTS	Total unladen: 13.900 kg Front axle unladen (boom retracted and lowered): 6.300 kg Rear axle unladen (boom retracted and lowered): 7.600 kg	
TRANSMISSION	Rexroth hydrostatics Variable displacement hydrostatic pump 85 cc with electronic control One variable displacement hydrostatic motor 115 cc Hydraulic gearbox with 2 speeds forward / reverse	
HYDRAULIC CIRCUIT	Load sensing piston pump 60 cc 132 l/min Circuit at 350 bar Electroproportional valve Suction and return line filters High pressure flexible hoses	
TANKS CAPACITIES	Engine oil = 16 l Colling liquid = 20 l Hydraulic oil tank = 210 l Fuel tank = 200 l	
TYRES DIMENSIONS	445/65 - R22,5 two each axle, driving and steering	
SAFETY	Electronic safety system which controls the load with definition of the lifted load, radius and comparison with the diagrams stored. Block of aggravating movements of the load. Safety valves on cylinders	

The data in this brochure are informative and subject to change without notice