

Technical sheet :

MI 30 G



	Technical characteristics		Metric
1.1	Manufacturer		Manitou
1.2	Model Name		MI 30 G
1.3	Power source		Lpg
1.4	Operator type		Seated
1.5	Max. capacity	Q	3000 kg
1.6	Load centre of gravity	c	500 mm
1.8	Load distance, centre of drive axle to fork	x	480 mm
1.9	Wheelbase	y	1700 mm
	Weight		
2.1	Service weight		4490 kg
2.2	Weight on front axle (laden) / rear axle (laden)		6560 kg / 930 kg
2.3	Weight on front axle (Unladen) / rear axle (Unladen)		1805 kg / 2685 kg
	Wheels		
3.1	Tyres type		PPS
3.2	Dimensions of front wheels		28-9-15 12
3.3	Dimensions of rear wheels		6.50-10 10
3.5	Number of front wheels / rear wheels		2 / 2
3.5.2	Number of drive wheels		2
3.6	Front wheel gauge	b10	1005 mm
3.7	Rear wheel gauge	b11	975 mm
	Dimensions		
4.1	Tilt of Mast Forward (deg) / Backward (deg)	α / β	6 / 12
4.7	Height of overhead guard (cabin)	h6	2130 mm
4.8	Seat height/stand height	h7	1215 mm
4.12	Height of towing bar (coupling height)	h10	355 mm
4.19	Overall length	l1	3865 mm
4.20	Length to face of forks	l2	2715 mm
4.21	Overall width	b1	1225 mm
4.22	Forks section / width / length	s / e / l	45 mm x 122 mm / 1150 mm
4.23	Fork carriage ISO 2328 (class/form) A/B		3A
4.24	Fork carriage width	b3	1100 mm
4.31	Ground clearance below mast	m1	130 mm
4.32	Ground clearance at centre of wheelbase	m2	200 mm
4.33	Aisle width for 1000 x 1200 pallet widthways	Ast	4140 m
4.34	Aisle width for 800 x 1200 pallet lengthways	Ast	4340 m
4.35	Turning radius	Wa	2460 mm
4.36	Internal turning radius (over tyres)	b13	160 mm
	Performances		
5.1	Travel speed (laden / unladen)		18 km/h / 18.5 km/h
5.2	Lifting speed (laden / unladen)		0.45 m/s / 0.55 m/s
5.3	Lowering speed (laden / unladen)		0.48 m/s / 0.5 m/s
5.5	Drawbar pull (Laden / Unladen)		1740 daN / 1080 daN
5.7	Gradeability (laden / unladen)		20 % / 20 %
5.10	Service brake		Hydraulic
	Engine		
7.1	Engine brand / model		GCT (ex-Nissan) / K25
7.2	Engine power according to ISO 1585		35 kW
7.3	Rated speed		2400 rpm
7.4	Number of cylinders / Capacity of cylinders		4 - 2488 cm ³
7.5	Fuel consumption according to VDI cycle		6.3 l/h
	Miscellaneous		
8.2	Working hydraulic pressure for attachments		160 Bar
8.3	Oil flow rate for attachments		72 l/min
8.4	Measured/guaranteed mean noise level at the ear of the operator		< 80 dB(A)

Dimensional drawing

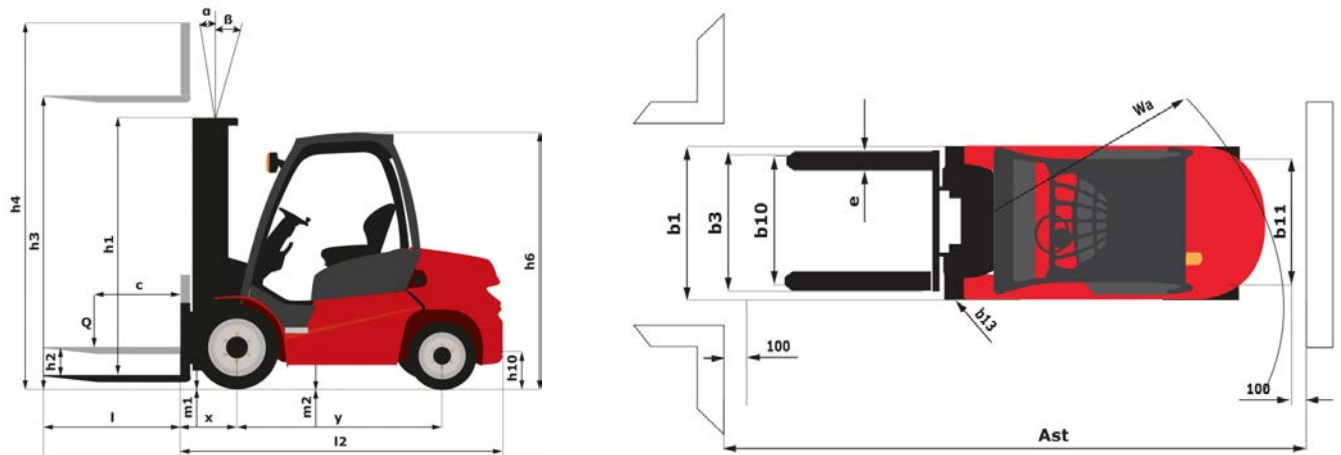

Characteristics of masts and residual capacities

Full Visibility Duplex		FVD 33	FVD 33	FVD 37	FVD 37	FVD 40	FVD 40
h1 - Height mast lowered *	mm	2200	2200	2450	2450	2650	2650
h2 - Free lift	mm	145	145	145	145	145	145
h3 - Lifting Height	mm	3300	3300	3700	3700	4000	4000
h4 - Height mast extended *	mm	4035	4035	4435	4435	4735	4735
α / β - Mast inclination (front / rear)	°	6 / 12	6 / 12	6 / 12	6 / 12	6 / 12	6 / 12
Height at max capacity	mm	3300	3300	3700	3700	4000	4000
Height at max capacity with integrated sideshift	mm	3300	3300	3700	3700	4000	4000
Residual capacity without attachment (Industrial load chart)	kg	3000	3000	3000	3000	3000	3000
Residual capacity with integrated side shift (Industrial load chart)	kg	3000	3000	3000	3000	3000	3000
Height at max capacity Fork positioner + DL	mm	3300	3300	3700	3700	4000	4000

Free Lift Duplex		FLD 33	FLD 33	FLD 37	FLD 40	FLD 40
h1 - Height mast lowered *	mm	2230	2230	2430	250	2580
h2 - Free lift	mm	1475	1475	1675	1825	1825
h3 - Lifting Height	mm	3300	3300	3700	4000	4000
h4 - Height mast extended *	mm	4055	4055	4455	4755	4755
α / β - Mast inclination (front / rear)	°	6 / 12	6 / 12	6 / 12	6 / 12	6 / 12
Height at max capacity	mm	3300	3300	3700	4000	4000
Height at max capacity with integrated sideshift	mm	3300	3300	3700	4000	4000
Residual capacity without attachment (Industrial load chart)	kg	3000	3000	3000	3000	3000
Residual capacity with integrated side shift (Industrial load chart)	kg	3000	3000	3000	3000	3000
Height at max capacity Fork positioner + DL	mm	3300	3300	3700		

Free Lift Triplex		FLT 43	FLT 45	FLT 47	FLT 48	FLT 50	FLT 55	FLT 60	FLT 65
h1 - Height mast lowered *	mm	2115	2165	2215	2265	2315	2515	2765	2915
h2 - Free lift	mm	1360	1410	1460	1510	1560	1760	2010	2160
h3 - Lifting Height	mm	4300	4500	4700	4800	5000	5500	6000	6500
h4 - Height mast extended *	mm	5055	5305	5455	5555	5755	6255	6805	7255
α / β - Mast inclination (front / rear)	°	6 / 6	6 / 6	6 / 6	6 / 6	6 / 6	3 / 6	3 / 6	3 / 6
Residual capacity at max height	kg	2950	2900	2800	2800	2500	1850	1400	1300

Free Lift Triplex		FLT 43	FLT 45	FLT 47	FLT 48	FLT 50	FLT 55	FLT 60	FLT 65
Residual capacity with hooked-on side shift (Industrial load chart)	kg								1250
Height at max capacity	mm	4000	4000	4000	4000	4000	4000	4000	
Height at max capacity with integrated sideshift	mm	4000	4000	4000	4000				
Residual capacity without attachment (Industrial load chart)	kg	2950	2900	2800	2800	2500	1850	1400	1300
Residual capacity with integrated side shift (Industrial load chart)	kg	2850	2800	2700	2700	2400	1750	1300	1250
Height at max capacity Fork positioner + DL	mm	4000	4000						

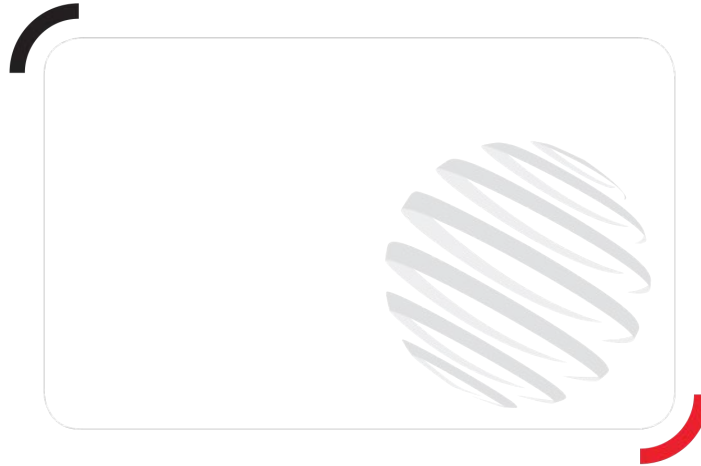

Siège Social
430 rue de l'Aubinière - 44150 Ancenis Cedex - France
Tel: +33(0)2 40 09 10 11 - Fax: +33 (0)2 40 09 10 97
www.manitou.com



This brochure describes versions and configuration options for Manitou products which may be fitted with different equipment. The equipment described in this brochure may be standard, optional or not available depending on version. Manitou reserves the right to change the specifications shown and described at any time and without prior warning. The manufacturer is not liable for the specifications given. For more information, contact your Manitou dealer. Non-contractual document. Product descriptions may differ from actual products. List of specifications is not comprehensive. The logos and visual identity of the company are the property of Manitou and may not be used without authorisation. All rights reserved. The photos and diagrams contained in this brochure are provided for information only.

MANITOU BF SA - Limited company with board of directors - Share capital: 39,668,399 euros - 857 802 508
RCS Nantes