

Technical sheet :

MI 50 G



	Technical characteristics		Metric
1.1	Manufacturer		Manitou
1.2	Model Name		MI 50 G
1.3	Power source		Lpg
1.4	Operator type		Seated
1.5	Max. capacity	Q	5000 kg
1.6	Load centre of gravity	c	500 mm
1.8	Load distance, centre of drive axle to fork	x	560 mm
1.9	Wheelbase	y	2150 mm
	Weight		
2.1	Service weight		6800 kg
2.2	Weight on front axle (laden) / rear axle (laden)		10450 kg / 1350 kg
2.3	Weight on front axle (Unladen) / rear axle (Unladen)		3000 kg / 3800 kg
	Wheels		
3.1	Tyres type		Pneumatic
3.2	Dimensions of front wheels		300-15-18PR
3.3	Dimensions of rear wheels		7.00-12-12PR
3.5	Number of front wheels / rear wheels		2 / 2
3.5.2	Number of drive wheels		2
3.6	Front wheel gauge	b10	1190 mm
3.7	Rear wheel gauge	b11	1130 mm
	Dimensions		
4.1	Tilt of Mast Forward (deg) / Backward (deg)	α / β	6 / 12
4.7	Height of overhead guard (cabin)	h6	2390 mm
4.8	Seat height/stand height	h7	1370 mm
4.12	Height of towing bar (coupling height)	h10	445 mm
4.19	Overall length	l1	4475 mm
4.20	Length to face of forks	l2	3255 mm
4.21	Overall width	b1	1490 mm
4.22	Forks section / width / length	s / e / l	50 mm x 150 mm / 1220 mm
4.23	Fork carriage ISO 2328 (class/form) A/B		3A
4.24	Fork carriage width	b3	1250 mm
4.31	Ground clearance below mast	m1	170 mm
4.32	Ground clearance at centre of wheelbase	m2	230 mm
4.33	Aisle width for 1000 x 1200 pallet widthways	Ast	4791 mm
4.34	Aisle width for 800 x 1200 pallet lengthways	Ast	4925 mm
4.35	Turning radius	Wa	2920 mm
4.36	Internal turning radius (over tyres)	b13	130 m
	Performances		
5.1	Travel speed (laden / unladen)		22 km/h / 24 km/h
5.2	Lifting speed (laden / unladen)		0.4 m/s / 0.43 m/s
5.3	Lowering speed (laden / unladen)		0.5 m/s / 0.5 m/s
5.5	Drawbar pull (Laden / Unladen)		3800 daN / 2300 daN
5.7	Gradeability (laden / unladen)		22 % / 32 %
5.10	Service brake		Hydraulic
	Engine		
7.1	Engine brand / model		PSI / 4,3L
7.2	Engine power according to ISO 1585		74 kW
7.3	Rated speed		2300 rpm
7.4	Number of cylinders / Capacity of cylinders		6 - 4300 cm ³
7.5	Fuel consumption according to VDI cycle		10.6 l/h
	Miscellaneous		
8.2	Working hydraulic pressure for attachments		160 Bar
8.3	Oil flow rate for attachments		90 l/min
8.4	Measured/guaranteed mean noise level at the ear of the operator		< 83 dB(A)

Dimensional drawing

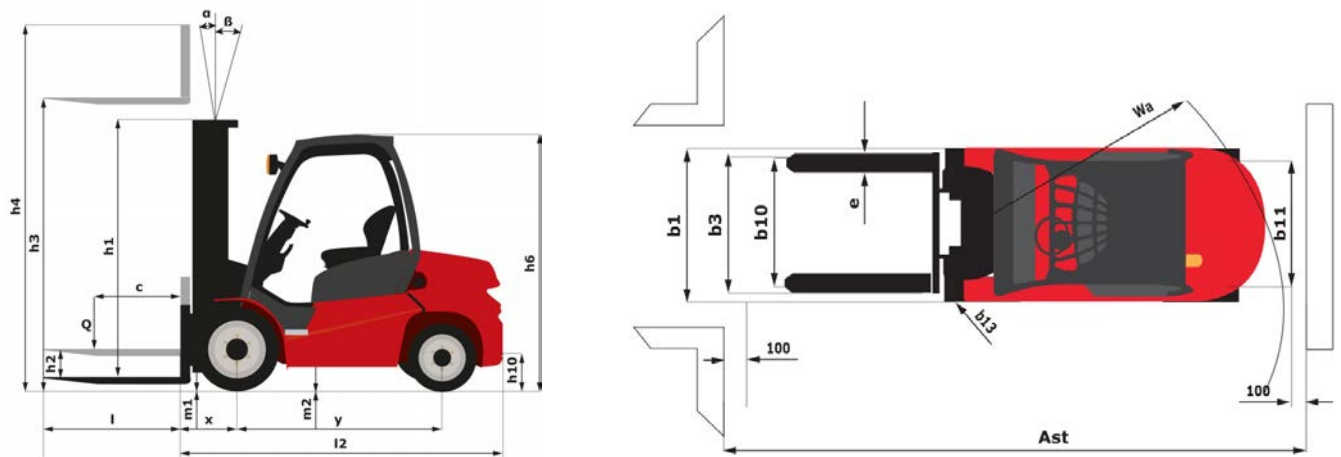

Characteristics of masts and residual capacities

Full Visibility Duplex		FVD 30	FVD 33	FVD 35	FVD 37	FVD 40	FVD 45	FVD 50
h1 - Height mast lowered *	mm	2245	2395	2495	2595	2795	3070	3345
h2 - Free lift	mm	160	160	160	160	160	160	160
h3 - Lifting Height	mm	3000	3300	3500	3700	4000	4500	5000
h4 - Height mast extended *	mm	4365	4665	4865	5065	5365	5865	6365
α / β - Mast inclination (front / rear)	°	6 / 12	6 / 12	6 / 12	6 / 12	6 / 12	6 / 6	6 / 6
Residual capacity at max height	kg	5000	5000	5000	5000	5000	4700	4100
Height at max capacity	mm	3000	3300	3500	3700	4000	4000	4000
Height at max capacity with integrated sideshift	mm	3000	3300	3500	3700	4000	4000	4000
Residual capacity without attachment (Industrial load chart)	kg	5000	5000	5000	5000	5000	4700	4100
Residual capacity with integrated side shift (Industrial load chart)	kg	5000	500	5000	5000	5000	4600	4000

Free Lift Duplex		FLD 30	FLD 33	FLD 35	FLD 37
h1 - Height mast lowered *	mm	2226	2376	2476	2576
h2 - Free lift	mm	1364	1514	1614	1714
h3 - Lifting Height	mm	3000	3300	3500	3700
h4 - Height mast extended *	mm	4365	4665	4865	5065
α / β - Mast inclination (front / rear)	°	6 / 12	6 / 12	6 / 12	6 / 12
Residual capacity at max height	kg	5000	5000	5000	5000
Height at max capacity	mm	3000	3300	3500	3700
Height at max capacity with integrated sideshift	mm	3000	3300	3500	3700
Residual capacity without attachment (Industrial load chart)	kg	5000	5000	5000	5000
Residual capacity with integrated side shift (Industrial load chart)	kg	500	5000	5000	5000

Free Lift Triplex		FLT 40	FLT 43	FLT 45	FLT 47	FLT 50	FLT 55	FLT 60
h1 - Height mast lowered *	mm	2080	2180	2248	2310	2410	2575	2790
h2 - Free lift	mm	1222	1322	1390	1452	1552	1718	1932
h3 - Lifting Height	mm	4000	4300	4500	4700	5000	5500	6000
h4 - Height mast extended *	mm	5365	5665	5880	6070	6370	6870	7380
α / β - Mast inclination (front / rear)	°	6 / 12	6 / 6	6 / 6	6 / 6	6 / 6	3 / 6	3 / 6
Residual capacity at max height	kg	4850	4700	4600	4300	3900	3400	2700
Residual capacity without attachment (Industrial load chart)	kg	4850	4700	4600	4300	3900	3400	2700

Free Lift Triplex	FLT 40	FLT 43	FLT 45	FLT 47	FLT 50	FLT 55	FLT 60
Residual capacity with integrated side shift (Industrial load chart) kg	4750	4600	4500	4200	3800	3300	2600



Siège Social
430 rue de l'Aubinière - 44150 Ancenis Cedex - France
Tel: +33(0)2 40 09 10 11 - Fax: +33 (0)2 40 09 10 97
www.manitou.com



This brochure describes versions and configuration options for Manitou products which may be fitted with different equipment. The equipment described in this brochure may be standard, optional or not available depending on version. Manitou reserves the right to change the specifications shown and described at any time and without prior warning. The manufacturer is not liable for the specifications given. For more information, contact your Manitou dealer. Non-contractual document. Product descriptions may differ from actual products. List of specifications is not comprehensive. The logos and visual identity of the company are the property of Manitou and may not be used without authorisation. All rights reserved. The photos and diagrams contained in this brochure are provided for information only.

MANITOU BF SA - Limited company with board of directors - Share capital: 39,668,399 euros - 857 802 508
RCS Nantes